

Enclosure series aluDISC

Type: AR 100

Material-No.: 280.100.000

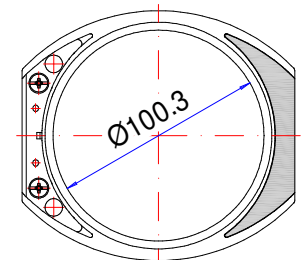
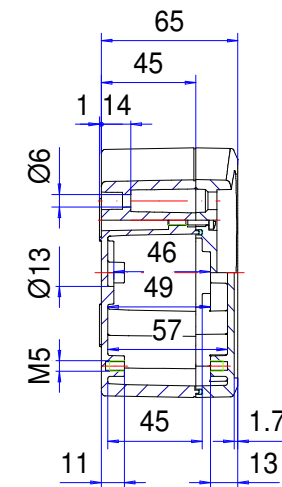
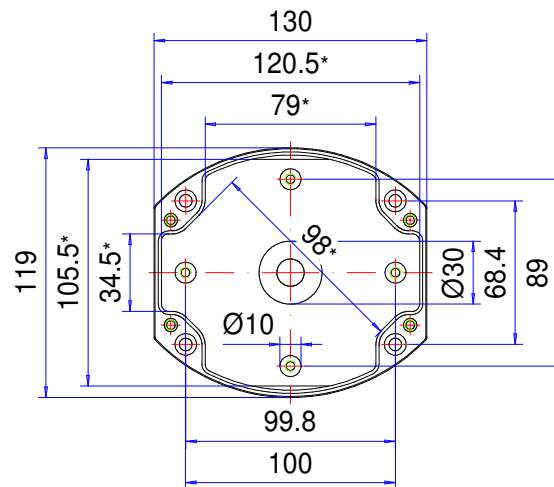
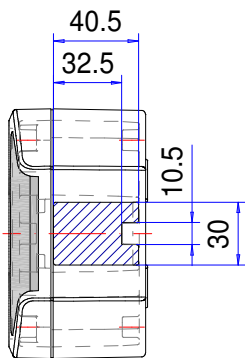
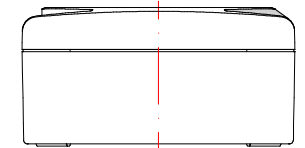
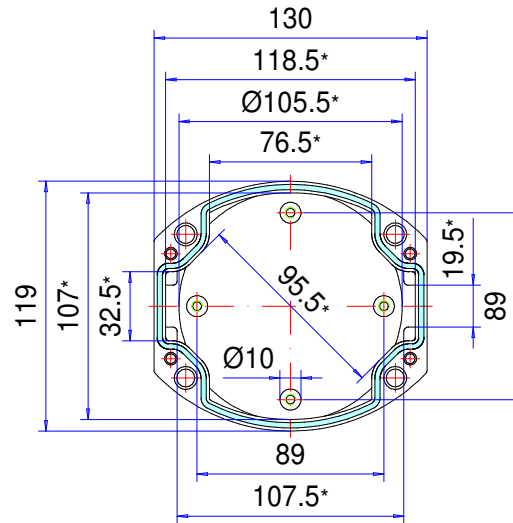

Folie/ Keypad
Ø99.7⁺⁰_{-0.2}

* Please note: Mould slope for casting ejection, dimensions in the amount of the bottom!

Enclosure material	EN AC-44300 (DIN EN 1706)		Ingress protection	IP66/67 EN 60529
Lid screws	4x stainless steel 1.4567 (V2A), captive		Weight	610 g
Assembly screws	5x M5x8, galvanized steel		Coating	Powder coating RAL 7035, light grey
Design covers	2x Polyoxymethylene (POM), RAL 7016, anthracite grey		Tolerance	DIN CEN ISO/TS 8062-2 (outside dimensions ±0,5mm)
Gasket	1x moulded gasket, silicone, red			